

INSTALLATION SHEET

SATURN recessed light fixture

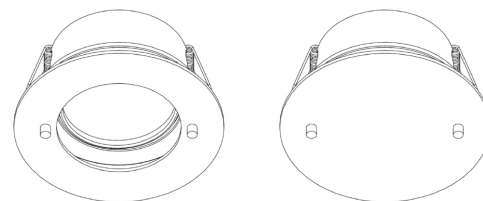

CUTOUT: Ø 2-3/8"
(Ø 60mm)

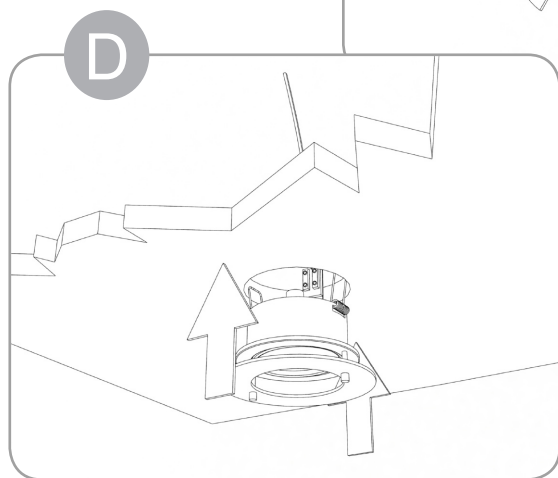
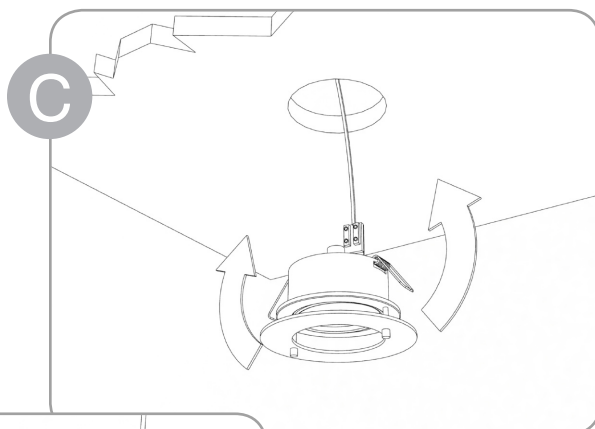
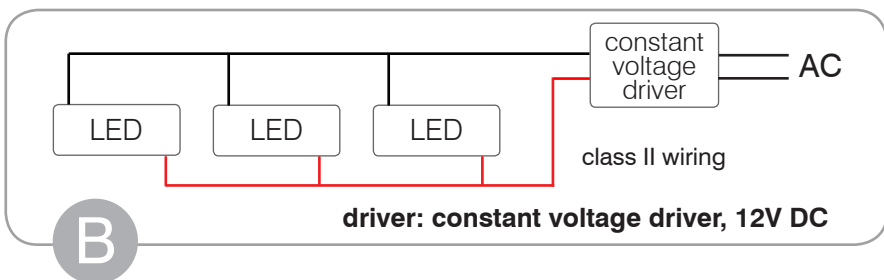
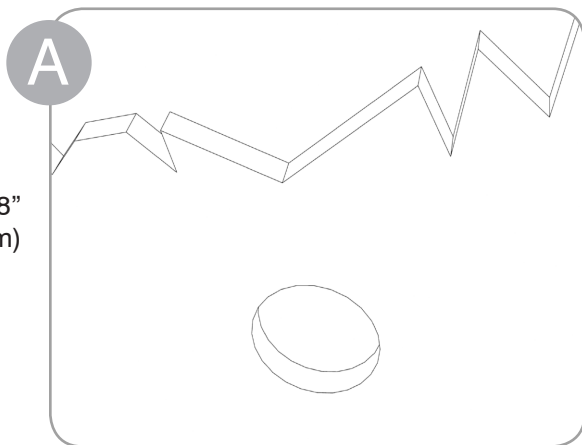

IMPORTANT INSTRUCTIONS

read and follow these instructions before installing or maintaining this product



location

- this product is suitable for **DRY INDOOR LOCATIONS ONLY**
- make sure this product is NOT on the same circuit as inductive loads, (e.g. fluorescent bulbs, discharge bulbs, ventilation fans, etc...)
- allow air to flow freely around the fixture
- **DO NOT INSTALL INSULATION WITHIN 3" (76mm) OF THE FIXTURE**
- ceiling thickness must be between 1/8" and 1" (3mm and 25.4mm)

safety

- Do not switch on line voltage until all wiring has been complete
- Incorrect wiring will result in irreparable damage to the LED and power supply
- This product should only be installed by a licensed electrician

INSTALLATION

switch off the line voltage supply

- A** cut a hole according to dimension
- B** connect wire to power supply (not included)
- C** flip the retention springs upward
- D** push the fixture in place



www.sensolighting.com
info@sensolighting.com
T 403.216.7043
F 403.216.7045



512 Manitou Road SE, Calgary, Alberta T2G 4C4

WARRANTY

- This product must be installed in accordance with all applicable installation codes and ordinance
- Limited two (2) years warranty
- Warranty is void in the eventuality of unauthorized modifications and/or improper use